



AUTON*omotor*

SENSORLESS • BRUSHLESS

24V BRUSHLESS DC MOTOR CONTROL
WITH SENSORLESS MOTOR COMMUTATION

► Introduction

Thank you for purchasing a Bison Sensorless BLDC Gearmotor and Speed Control. Considerable effort has been invested to provide a robust, durable product for use in your equipment.

This line of BLDC speed controls has been developed to work exclusively with Bison’s 24V BLDC sensorless motor. The drives have been factory calibrated with predetermined settings of current limit, minimum and maximum speed range and other settings allowing the sensorless drive to operate with Bison’s line of sensorless BLDC motors.

This drive is intended for use in single quadrant applications. No braking capability is built into this drive and motor combination. The drive is programmed to be used in velocity control applications and does not have regenerative capabilities to control speed in braking or over-running applications.

APPLIES TO THE FOLLOWING BISON PRODUCTS:

Gearmotor & Drive	RPM Hi (2500)	RPM Low (500)	Rated Torque (In-Lb)	Rated Torque (N-m)	Peak Torque (In-Lb)	Peak Torque (N-m)	Peak Current RMS	Motor Input Hp	Motor Input Watts	Gear Ratio	# Stages
012-200-9216	12	2	275	31	310	35	2.8	1/10	74	215.6	3
012-200-9170	15	3	250	28	275	31	3.3	1/10	74	170.0	3
012-200-9102	24	5	242	27	275	31	4.5	1/10	74	102.4	3
012-200-9082	31	6	193	22	250	28	4.6	1/10	74	81.8	3
012-200-9058	43	9	226	26	325	37	7.0	1/6	124	58.3	3
012-200-9043	58	12	166	19	190	21	7.0	1/6	124	42.9	3
012-200-9028	89	18	114	13	145	16	7.0	1/6	124	28.0	2
012-200-9019	131	26	77	9	100	11	7.5	1/6	124	19.0	2
012-200-9015	167	33	61	7	80	9	7.8	1/6	124	15.0	2
012-200-9011	236	47	43	5	55	6	8.0	1/6	124	10.6	2
012-200-9005	500	100	20	2	25	3	9.0	1/6	124	5.0	2

► Safety Warnings

- Do not install, remove, or rewire this equipment with the power connected.
- Have a qualified electrical technician install, adjust and service this equipment.
- Follow the National Electrical Code and all other applicable electrical and safety codes, including the provisions of the Occupational Safety and Health Act (OSHA) when installing equipment.
- Reduce the chance of an electrical fire, shock, or explosion by using proper grounding, over-current protection, thermal protection and enclosure.
- Install a master switch in the main power input to stop the drive in an emergency.

► What is Supplied:

1. Bison Sensorless Control #170-400-XXXX
2. (5) insulated 0.187" female crimp-on connectors for customer supplied power conductors
3. (1) 3' long control cable (non-shielded) with Tyco plug #172331. Customer end of this cable has leads stripped ¼" for customer side connections.
4. (1) 10K single turn potentiometer

► Warranty Policy

The Company warrants to the Buyer the products sold hereunder to be free of defects in material and workmanship under normal use and service for a period of one (1) year from the date of shipment. The obligation of the Company under this warranty is limited to repair or replacing at its option, any part or parts, which upon examination shall disclose to the reasonable satisfaction of the Company to have been defective in material or workmanship. Buyer must return the products to the Company's factory, shipping charges prepaid, and with complete information as to alleged defects and the installation, operation and service of the products. Except as otherwise expressly stated herein the Company makes no representation of warranty of any kind, express or implied, as to merchantability, fitness for a particular purpose, or any other matter with respect to the products sold hereunder.

► Operation

- Input motor and speed control are designed to run at 500 to 2500 RPM prior to being reduced in speed by the gear reduction. Actual RPM limits will vary slightly and will be within 20 RPM of stated values at the input.
- Input motor and speed control are programmed to provide constant velocity through the specified torque range. Once the RPM has been set the product will deliver near constant velocity over the torque range from zero through rated torque.
- Peak torque (maximum allowable design torque) has been listed to specify the maximum load the gearmotor can manage on an intermittent basis. Bison's brushless DC gearmotors and drives are capable of delivering substantially more torque than listed, with possible detrimental effects to the geartrain, bearings and motor elements.
- Stall Conditions: The drive has been pre-programmed with an appropriate level of current limit to protect the motor and geartrain from damage due to excessive torque loads. If the gearmotor is stalled due to excessive torque, the drive will attempt to start the gearmotor three times in rapid succession. If the motor will not start after three attempts, power will need to be cycled on and off to reset the stall counter in the control program. If the gearmotor experiences repeated stalling, this indicates that the load is larger than the unit can handle, and damage may occur to system components.

► Mounting the Drive

- Mount the drive in an area free of dirt, moisture and accidental contact.
- Choose a location that is not near heat sources. The drive is suitable for mounting in 40°C (104°F) ambient temperature, maximum.
- Provide sufficient room for access to the terminals.
- The drive is to be located within 3 feet of the gearmotor and within 3 feet of the power supply.
- Using appropriate fasteners, mount the drive securely with (4) #8-32 screws.
- The chassis must be earth grounded. Use a star washer beneath the head of one of the mounting screws to penetrate the anodized chassis surface and to reach bare metal.

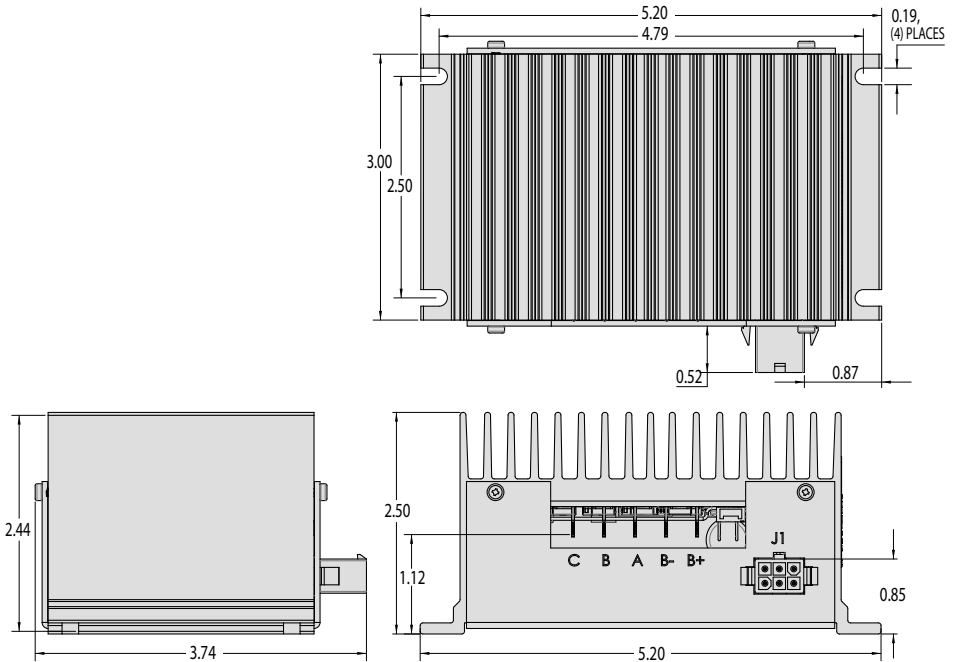

► Connections

There are three sets of connections to be made for the BLDC system installation.

1. Power supply to drive
2. Drive to motor
3. Control cable to run/stop, forward/reverse, tachometer output components

						Bison Sensorless Control #170-400-xxxx	
Cable Info		Lead Color	Ga	Info	Connectors	5	Male spade terminals
Motor	Motor cable	C Blue	16	4 conductor power cable (3 motor leads plus ground), 16 gage, 3 feet maximum	Keystone Male Terminal 0.187" #4907 or equivalent	C	Phase C
		B Yellow				B	Phase B
		A Red				A	Phase A
24V DC Power Supply (200W for 1/6 Hp, 120W for 1/10 Hp)	Power cable	White	16	3 conductor power cable (2 power leads plus ground), 16 gage, 3 feet maximum		B-	Ground
		Black				B+	+24V DC
						J1	Female plug on drive
Potentiometer or PLC speed control connection. Pin 1 not needed for PLC connection.	Control cable #191-000-1002	Orange	26	Supplied cable to be routed and connected to customer I/O components to control Run/Stop, direction of rotation, speed of rotation and tachometer output.	Tyco Housing #172331 (6) pins	1	5VDC
		Black				2	0-5VDC Analog Signal
White		3				Common	
24V (B+) to Run, open for Stop		4				Run/Stop	
24V (B-) Forward, open for Reverse		5				Forward/Reverse	
24V (B-) Digital PWM Signal *	Blue	6	Tach Outpt, 60 Pulses/Rev				

* The levels are approximately B+ when HI and approximately B- when LO. The output is a 50% duty cycle PWM with a frequency dependent on the motor speed. 60 Pulses per revolution of motor shaft (not output shaft of gearmotor.)

Power supply to drive

The power supply should be located as close as possible to the drive and connected using 16 gage multi-stranded wiring rated for 105°C minimum temperature rating. A fuse rated at 150% of the rated current should be installed per the connection diagram. If the power supply needs to be located further than 3 feet away, use (2) 14 gage multi-stranded wires twisted (one twist per inch), no more than 12 feet long. The supply line to the power supply should include a disconnect switch per national electrical code guidelines.

Drive to the motor

The motor should be located as close as possible to the drive, and connected using (3) 16 gage multi-stranded wires rated for 105°C minimum temperature rating. Connections should be made per the wiring diagram. The power leads are the only connections; there are no feedback leads as with other BLDC products. If the motor needs to be located more than 3 feet away, use (3) 14 gage multi-stranded wires twisted (one twist per inch), no further than 12 feet long.

Control cable to customer supplied components

A 3-foot long control cable is supplied with the drive for use in controlling the BLDC gearmotor system.

The cable is for connection to:

- The supplied 10K potentiometer (or customer PLC) for speed control
- Run/Stop control
- Forward/Reverse control
- Tachometer digital display

This cable is not shielded and therefore needs to be placed apart from power conductors. The cable should be as short as possible to minimize effects from EMI sources. In extremely high EMI environments, additional measures may be needed for effective control and are the responsibility of the customer to properly shield control wiring.

► **Connection Diagram:**

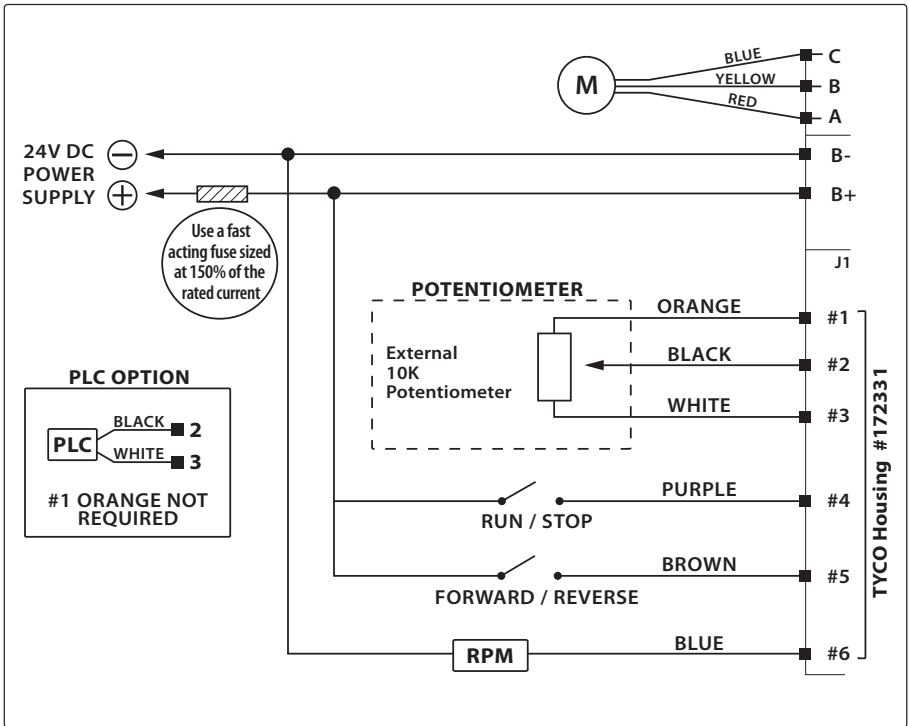

Run/Stop Control

Typically connected to a toggle switch or normally open (NO) switch. Initial state is off. Once engaged or closed, the run/stop will start the motor. This switch does not disconnect the power to the drive.

Forward/Reverse Control

Typically connected to a two pole toggle switch, the forward/reverse manages the rotation direction of the motor. The motor must be at a stop prior to reversing. If the forward/reverse is changed while the motor is running nothing will happen until the run/stop stops the motor. When the motor is run again the direction will be in synch with the appropriate direction of the switch.

Tachometer Control

This is a digital PWM signal that equates to 60 pulses per revolution of the motor. When connected to a frequency counter (or adjustable time-base rate indicator) or PLC the signal can be used for motor RPM feedback. The levels are approximately B+ when HI and approximately B- when LO. The output is a 50% duty cycle PWM with a frequency dependent on the motor speed. **Note:** when used with a gearmotor the signal will need to be divided by the gear ratio to obtain output shaft RPM.

► Performance Curves

012-200-9005 • 170-400-A001

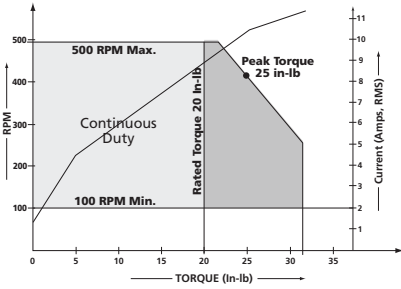

012-200-9011 • 170-400-4001

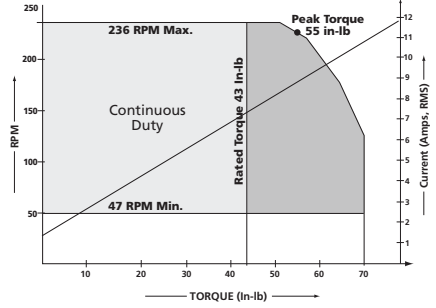

012-200-9028 • 170-400-A001

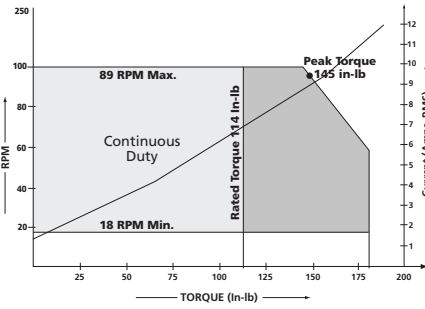

012-200-9043 • 170-400-A001

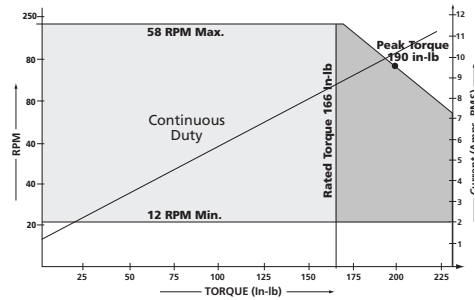

012-200-9102 • 170-400-B002

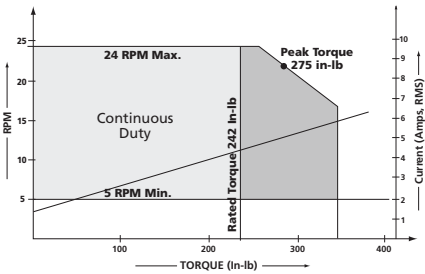

012-200-9170 • 170-400-B003

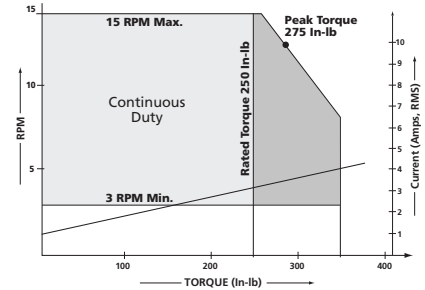

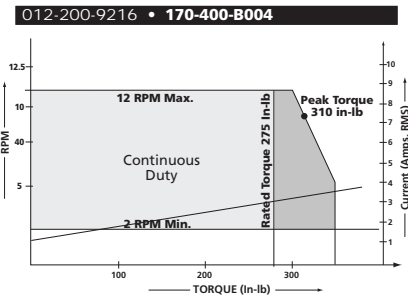
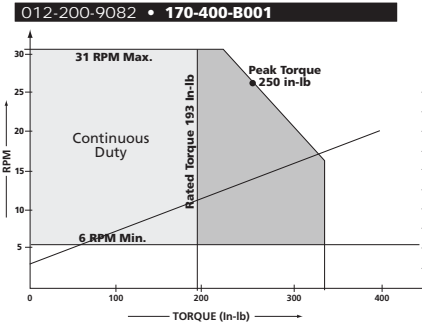
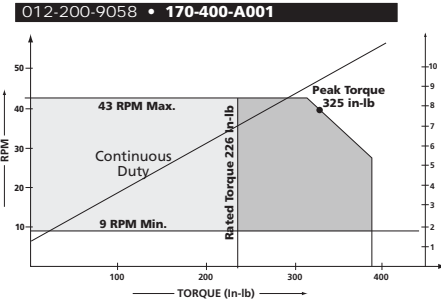
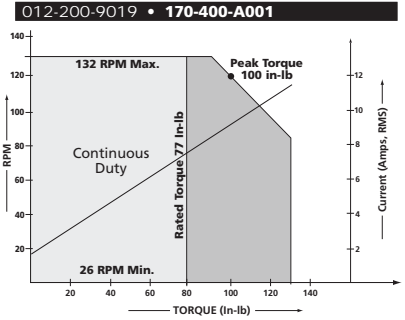
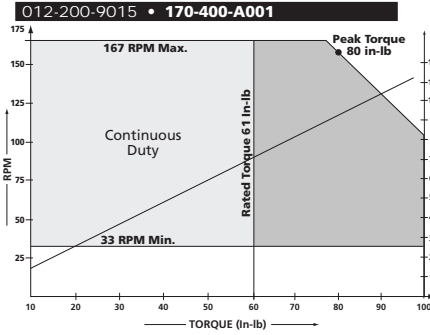

Agency Information:

Motor: Class F insulation system evaluated to UL 1449, component recognized in E199928. Construction features meet UL 1004 and C22.2 #100, component recognized in E89715.

Drive: This three phase brushless DC drive has been evaluated to UL508C and C22.2 No. 14-2010, component recognized in E324566.

► Frequently Asked Questions

- 1. What is the demagnetization current?**
Approximately 35 amps for the 1/6 hp unit, and 25 amps for the 1/10 hp unit.
The current is limited by the control to prevent demag from occurring.
- 2. Can the control settings be modified?**
No, the control is programmed at the factory for each motor. OEM order quantities (500 units and up) may be considered for special programming.
- 3. Is the potentiometer supplied?**
Yes, a standard 10K potentiometer is supplied.
- 4. What is the definition of Peak Torque?**
Peak torque is the allowable intermittent torque that a gearmotor may experience during operation, not to be exceeded. Consult factory to review application.
- 5. Why Sensorless? Why is it better?**
Sensorless control offers a simplified approach for applications typically associated with velocity control. The need for a separate feedback cable is eliminated. Aesthetics are improved with less connection hardware. Fewer parts improve quality and durability.
- 6. Is the system difficult to connect?**
Simplified set-up. Competitors drives have "hook up procedure for motors with timing diagrams" and "hook up procedures for motors without timing diagrams". Also, "setting current limits". Our drive is pre-programmed, plug & play.
- 7. Can we incorporate an encoder?**
The standard unit as-is does not have a shaft extension for encoder or provisions for mounting. OEM order quantities (500 units and up) are required for non standard designs.
- 8. What is the expected starting torque on these units?**
The starting torque is at least 150% rated torque. Starting is robust with BLDC units in general.
- 9. Can I use this in a regenerative application?**
No, this is a single quadrant drive used for applications that do not require braking.
The drive will not change direction without stopping first.
- 10. My gearmotor stalled and will not restart, how do I restart the unit?**
The control program will attempt to start the gearmotor three times when stalled in rapid succession. If the unit fails to start after three attempts it will not start until power is cycled on and off to the speed control. Stall conditions should rarely occur; if they are occurring frequently the gearmotor is at risk of permanent damage and should be taken out of service to prevent failure.

Copyright © 2011 by Bison Gear & Engineering

All rights reserved. No part of this manual may be reproduced or transmitted in any form without written permission from Bison Gear & Engineering. The information and technical data in this manual are subject to change without notice. Bison Gear & Engineering and its divisions make no warranty of any kind with respect to this material, including, but not limited to, the implied warranties of its merchantability and fitness for a given purpose. Bison Gear & Engineering and its Divisions assume no responsibility for any errors that may appear in this manual and make no commitment to update or to keep current the information in this manual.



Ph: 800-AT-BISON • Int'l. Ph: 1-630-377-4327
Email: info@bisongear.com • www.bisongear.com

Printed in the USA
0010000411